

EQUIPMENT CATALOG 2014



BWM



HOPKINS

A Division of **BWM**



Alabama

TUBELITE

Birmingham (800) 505-4900

SCREEN PROCESS OF ALABAMA

Trussville (800) 804-0786

Arizona

TUBELITE

Phoenix (800) 505-4900

California

ALL-TEX INK CORP.

La Mirada (714) 562-8881

BECKMAR, LLC

Orange (714) 289-4435

COASTAL SUPPLY

Santee (619) 562-8880

DENCO SALES

Fresno (800) 640-4151

J. HOPKINS CO.

Hayward (510) 276-1659

MCLOGAN SUPPLY

San Diego (619) 595-0270

MCLOGAN SUPPLY

Los Angeles (213) 749-2262

MCLOGAN SUPPLY

Anaheim (714) 999-1194

MCLOGAN SUPPLY

Chatsworth (818) 718-0888

MIDWEST SIGN

Hayward (800) 824-2468

NAZDAR

Garden Grove (800) 252-7767

PARMELE SCREEN PROCESS SUPPLIES, INC.

N. Hollywood (800) 223-4PSP

RESOURCE GROUP

Oakdale (866) 845-8228

SCREEN PRINTERS RESOURCE

Fullerton (888) 435-2468

Colorado

DENCO SALES

Denver (800) 232-0607

ROCKSTAR SCREEN SUPPLY

Denver (866) 468-6776

Connecticut

GARSTON SUPPLY

E. Hartford (800) 966-9626

Florida

TUBELITE

Apopka (800) 505-4900

SCREEN PROCESS OF ALABAMA

Jacksonville (800) 804-0786

TUBELITE

Miami (800) 505-4900

TW GRAPHICS

Longwood (800) 262-3051

Georgia

NAZDAR

Norcross (800) 537-4606

REECE SUPPLY COMPANY OF GEORGIA

Norcross (800) 776-0115

Hawaii

ONE SHOT SUPPLIES

Honolulu (808) 841-7683

Illinois

NAZDAR

Elk Grove Village (847) 439-8668

Indiana

TUBELITE

Indianapolis (800) 505-4900

Iowa

SPSI

(800) 876-7774

Kansas

NAZDAR

Shawnee (800) 767-9942

SPSI

Lenexa (800) 876-7774

Louisiana

GRAPHIC SOLUTIONS GROUP

Baton Rouge (225) 274-3800

REECE SUPPLY COMPANY OF LOUISIANA

Harahan (800) 776-0130

Massachusetts

COMMERCIAL SCREEN SUPPLY

Avon (508) 583-2300

GARSTON SUPPLY

Haverhill (978) 374-0600

Michigan

NAZDAR

Troy (800) 733-9942

Minnesota

MIDWEST SIGN

St. Paul (800) 328-6599

SPSI

Maple Grove (800) 876-7774

Missouri

MIDWEST SIGN

Kansas City (800) 233-3770

Nevada

SOUTHWEST SILKSCREENING STORE

Las Vegas (702) 641-6005

New Jersey

ALL-PRO PRESS SERVICE

Plainsboro (732) 735-2097

NAZDAR

Pennsauken (800) 257-8226

TUBELITE

Moonachie (800) 505-4900

New Mexico

DENCO SALES

Albuquerque (505) 830-0212

New York

GARSTON SUPPLY

Rochester (585) 321-1610

REICH SUPPLY

New Hartford (800) 338-3322

North Carolina

NAZDAR

Greensboro (800) 426-0290

REECE SUPPLY COMPANY OF NORTH CAROLINA

Charlotte (855) 425-1140

TUBELITE

Charlotte (800) 505-4900

Ohio

JAY PRODUCTS

Cincinnati (800) 543-4436

NAZDAR

Cincinnati (513) 870-5706

TUBELITE

Columbus (800) 505-4900

Oklahoma

GRAPHIC SOLUTIONS GROUP

Oklahoma City (800) 677-3149

GRAPHIC SOLUTIONS GROUP

Tulsa (918) 664-2226

REECE SUPPLY COMPANY OF OKLAHOMA

Tulsa (800) 520-2300

Oregon

DENCO SALES

Portland (800) 345-0172

MIDWEST SIGN

Portland (800) 228-0596

NORTHWEST SIGN SUPPLY

Portland (800) 873-0111

Pennsylvania

POCONO SCREEN SUPPLY, LLC

Scranton (888) 637-4835

Tennessee

TUBELITE

Memphis (901) 396-8320

Texas

GRAPHIC SOLUTIONS GROUP

Dallas (800) 366-1776

Texas (continued)

GRAPHIC SOLUTIONS GROUP

Houston (800) 775-7545

LEE'S SCREEN SUPPLY

Stafford (800) 447-8874

REECE SUPPLY COMPANY OF DALLAS

Irving (800) 776-7448

REECE SUPPLY COMPANY OF EL PASO

El Paso (877) 776-0128

REECE SUPPLY COMPANY OF HOUSTON

Houston (800) 776-0113

REECE SUPPLY COMPANY OF SAN ANTONIO

San Antonio (800) 776-0224

SPSI

Arlington (800) 876-7774

Utah

REGIONAL SUPPLY

West Salt Lake City (800) 365-8920

Washington

DENCO SALES

Seattle (800) 334-3406

DIMENSIONAL PRODUCTS CORPORATION

Seattle (877) 881-4577

Wisconsin

SPSI

Saukville (800) 876-7744

Canada

WILLOX GRAPHIC SUPPLIES

Vancouver (800) 561-8844

United Kingdom

DAVE RENTON SCREENPRINTING SUPPLIES

+44(0)191 461 0318

Holland

VIPROTECH

+31 23 531 91 23

Japan

YOSHIKAWA CHEMICAL CO

Osaka 0081-6-6266-2251

Sweden

SCHNEIDLER GRAFISKA AB

Kista +46 (0)8-6325000

Belgium

MINERVA TEXTILES INTERNATIONAL

Belgium 32.2.569.42.69

Chile

SCRENGRAF

Santiago (02) 496 05 00

Russia

AGALSEA

+7 (499) 408-1864



QUALITY *you can* TRUST

FOR OVER 35 YEARS, our line of screen printing equipment has been meeting and exceeding our customers' needs. Built to last and designed for professional use, we stand behind the quality of our equipment with a 2 year warranty.

DESIGNED *for* PROFESSIONALS



Our wrenchless registration allows total control over screen adjustment without tools



Adjust the screen angle, X and Y axis and off contact independently



Pedestal style base has a small footprint in your shop



Modular design means you only replace parts as they wear, which lowers the cost of maintenance



Durable and rigid all aluminum print heads stand the test of time

DEPENDABLE SERVICE



Dedicated customer service staff available to help you with maintenance, repair, or replacement parts



We offer full restoration and repairs on older Hopkins presses



A two year warranty is standard on all new equipment purchases

MADE *in the* USA



We are proud to manufacture all our equipment in the USA.

Startingline™ Bench Model Manual Press

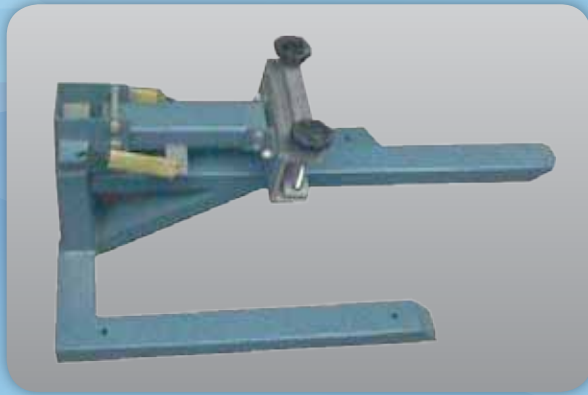

Startingline Bench Model 1/1 with optional stand



Startingline Bench Model 4/1
with optional stand



Startingline Bench Model 4/2 with optional stand



Scan to
view
product
info
online

The BWM/Hopkins Bench Model Press is designed with ease of use & simplicity in mind. This compact press is built for table top use and is ready for printing right out of the box. An optional stand is available. Choose from a 1 color 1 station press or a 4 color 1 or 2 station press. Expect years of production from this durable unit. A two-year parts warranty is standard on all new BWM/Hopkins presses.

FEATURES

- Extruded Aluminum Clamp
- 1 or 2 Print Stations
- 14" X 14" Shirt Board Included
- Durable Powder Coated Finish

SPECIFICATIONS

1 color	1 station
4 color	1 station
4 color	2 station

OPTIONS

- Universal Side Clamps
- Multitude of Different Sizes and Types of Pallets
- Jacket Hold Downs
- Aluminum Shirtboards
- Custom Print Stations
- Custom Powder Coating Colors/Finishes
- Stand

Startingline™ Manual Press

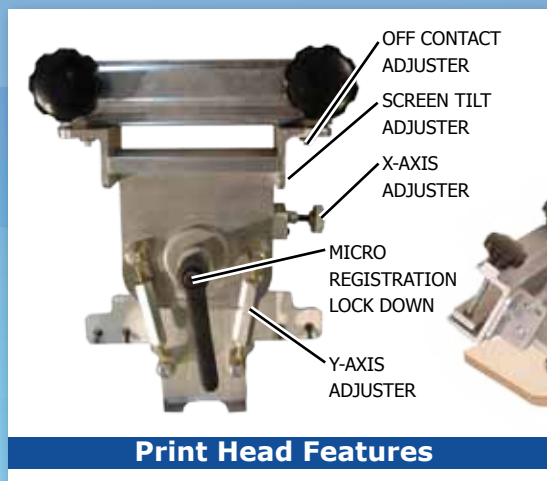

The BWM/Hopkins Startingline™ press provides the small shop printer with a feature filled, affordably priced press. Available in a 4 color, single/dual station bench model or, pick from a full line of floor models that include a choice of 4 or 6 color model with up to 4 print stations. The Startingline™ series of presses use precision laser cutting for the base, indexer, and print head wheel. Print heads are extruded and machined from aircraft quality aluminum. Standard micros on all floor model print heads put this economically priced press in a league of it's own. Quality, Performance, & Durability... What else would you expect from BWM/Hopkins? Preferred by manual printers for more than 35 years. A two-year parts warranty is standard on all new BWM/Hopkins presses.



**Scan to
view
product
info
online**

FEATURES

- Micro Registration
- All Aluminum Print Heads
- Positive Lock Registration Gate
- Pedestal Style Base
- Industrial Grade Bearings
- Durable Powder Coated Finish
- 4 or 6 Print Heads
- 14" X 14" Shirt Boards Included
- Leg Levelers

OPTIONS

- Universal Side Clamps
- Multitude of Different Sizes and Types of Pallets
- Jacket Hold Downs
- Aluminum Shirtboards
- Custom Powder Coating Colors/Finishes
- Casters

SPECIFICATIONS

		Press Diameter
4 color	4 station	79"
6 color	4 station	85"



Copyright 2014 BWM/Hopkins, a division of Billington Welding & Manufacturing, Inc. All rights reserved. No information herein may be reproduced or used in any manner without prior, express written consent from BWM/Hopkins. BWM/Hopkins, a division of Billington Welding & Manufacturing, Inc. (hereinafter BWM/Hopkins), believes the information in this document to be accurate at publication and does not assume liability resulting from incompleteness or inaccuracy. BWM/Hopkins reserves the right to change features, options, and/or specifications without notice. No warranties of merchantability or fitness for a particular purpose are made or are to be implied from the information herein. BWM/Hopkins expressly disclaims any liability for damages, consequential or incidental, from purchase, installation, servicing, and/or use of any product/service based upon the information herein. Published 01/13/14.

Convertible™ Manual Press

Print Head Features



See Page 11 for
Optional Side Clamps

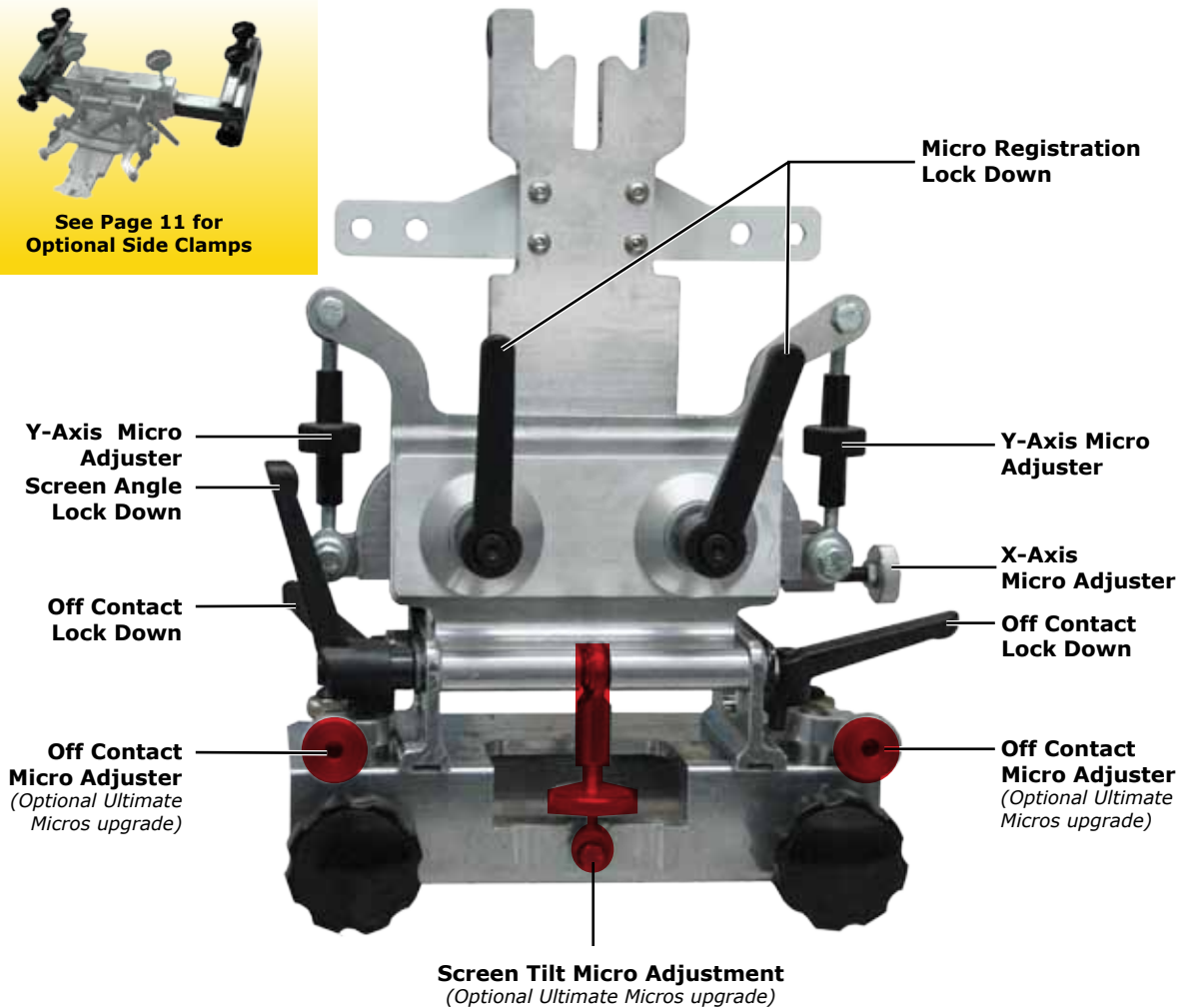

SPECIFICATIONS

		Max. Screen OD	Press Diameter	Large 35" Dia. Wheel
4 color	4 station	26"	92"	
6 color	4 station	23"	92"	
6 color	6 station	23"	92"	
6 color	4 station	26"	103"	✓
6 color	6 station	26"	103"	✓
8 color	4 station	23"	103"	✓
8 color	6 station	23"	103"	✓
8 color	8 station	23"	103"	✓

Convertible™ Manual Press



Scan to
view
product
info
online

Built with BWM/Hopkins quality and integrity, loaded with standard features at a value price, this BWM/Hopkins press is designed to give years of service. As your screen printing needs grow, you can upgrade the 4 color model to a 6 color press or convert the large 6 color model to an 8 color press. The print head wheel and rotary base are precision laser cut out of steel. This makes it light, strong, and extremely rigid so registration is not compromised. Both print head wheel and print station wheel rotate on large 2" diameter industrial grade bearings. Print heads are 100% wrenchless! No tools necessary! A two-year parts warranty is standard on all new BWM/Hopkins presses.

FEATURES

- | | |
|---|-------------------------------|
| Micro Registration | Adjustable Roller Bearing Cam |
| Industrial Grade Bearings | Indexing System (RB) |
| Extruded Aluminum Clamp | Positive Lock Indexing System |
| All Aluminum Print Heads | Pedestal Style Base |
| 100% Wrenchless™ | 2" Diameter Shaft |
| 4, 6 or 8 Print Heads | Leg Levelers |
| 4, 6 or 8 Print Stations | Durable Powder Coated Finish |
| 16" x 16" Shirtboard included
for each print station | |

OPTIONS

- | | |
|---|--|
| Ultimate Micros™ | Aluminum Shirtboards |
| • Dual Independent
Off-contact Micro
Adjustment | Large Diameter Print Head
Wheel |
| • Screen Tilt Micro Adjustment | Large Diameter
Print Station Wheel |
| Side Clamps | Custom Print Station |
| Universal Side Clamps | Casters |
| Multitude of Different Sizes
and Types of Pallets | Custom Powder Coating
colors / finishes |
| Jacket Hold Downs | |



Copyright 2014 BWM/Hopkins, a division of Billington Welding & Manufacturing, Inc. All rights reserved. No information herein may be reproduced or used in any manner without prior, express written consent from BWM/Hopkins. BWM/Hopkins, a division of Billington Welding & Manufacturing, Inc. (hereinafter BWM/Hopkins), believes the information in this document to be accurate at publication and does not assume liability resulting from incompleteness or inaccuracy. BWM/Hopkins reserves the right to change features, options, and/or specifications without notice. No warranties of merchantability or fitness for a particular purpose are made or are to be implied from the information herein. BWM/Hopkins expressly disclaims any liability for damages, consequential or incidental, from purchase, installation, servicing, and/or use of any product/service based upon the information herein. Published 01/13/14.

ProLine IITM

Manual Press

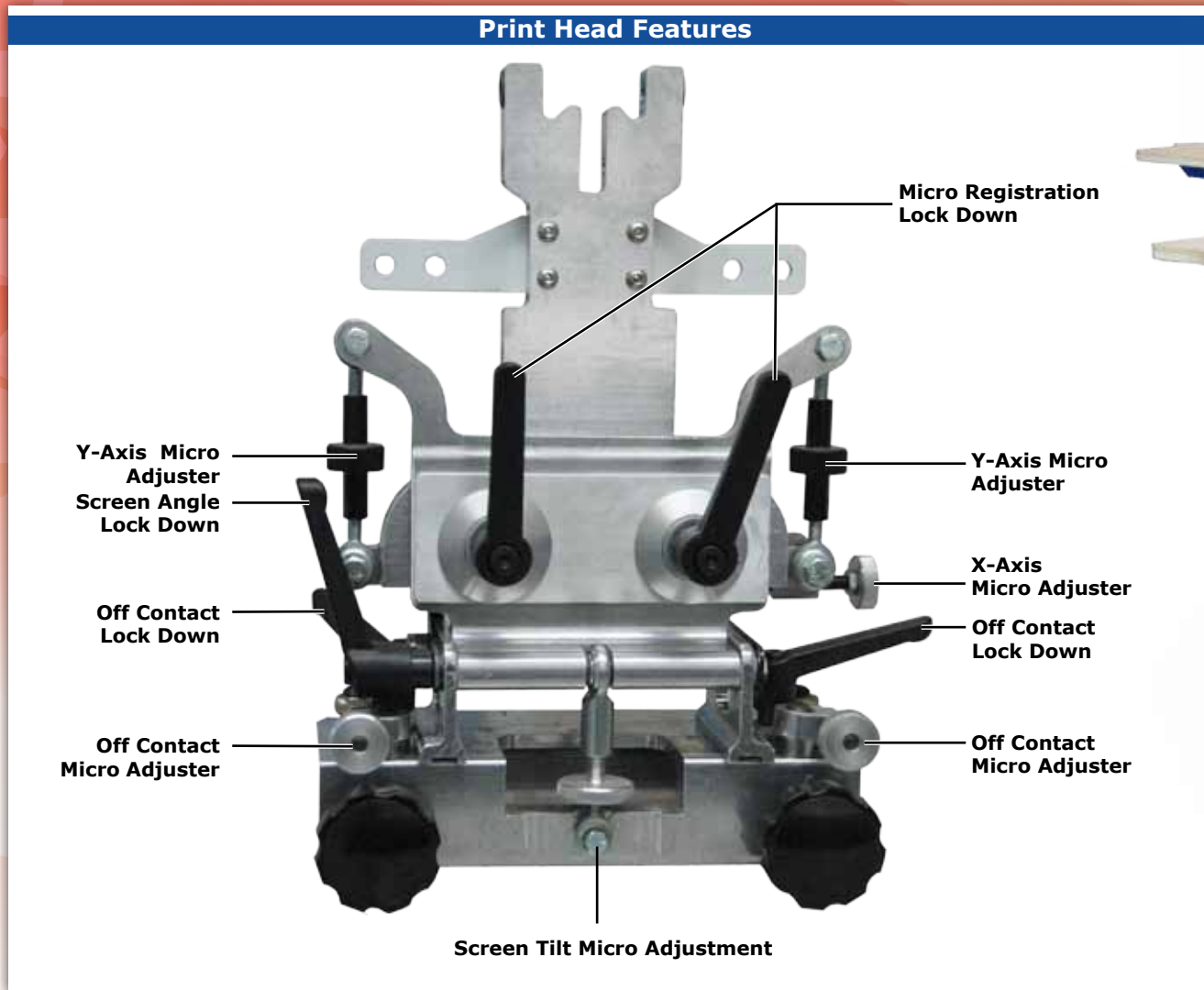

SPECIFICATIONS

		Press Diameter	Shaft	Indexing System
4 color	4 station	86"	2"	Roller Bearing
6 color	4 station	98"	2"	Roller Bearing
6 color	6 station	98"	2"	Roller Bearing
8 color	4 station	123"	2.5"	Roller Bearing
8 color	6 station	123"	2.5"	Roller Bearing
8 color	8 station	123"	2.5"	Roller Bearing

Jumbo Proline Presses also available. Contact us at info@bwmhopkins.com or (800) 932-9312 for details.



Proline Jumbo 14 Color

Introducing the **NEW**

ProLine II™

Manual Press



ULTIMATE MICROS INCLUDED

All ProLineII printheads come standard with independent X and Y axis, off contact, and screen tilt micro-adjustments.

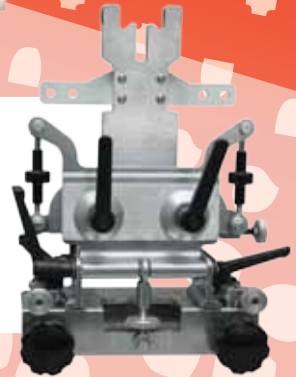

We are proud to introduce the newest member of our screen printing family, the ProLineII™. Built with the same Hopkins quality and integrity as the original ProLine™, this press is built with a precision machined solid billet aluminum print head wheel that is ultralight and sturdy. The all aluminum printheads include our Ultimate Micros™ which offer dual independent off-contact micro adjustment and screen tilt micro adjustment, in addition to the X and Y axis micro adjusters. All of which can be adjusted without tools. Both print head wheel and print station wheel rotate on large diameter industrial grade bearings.

FEATURES

- Solid Billet Aluminum Print Head Wheel
- Industrial Grade Bearings
- Extruded Aluminum Clamp
- Billet Aluminum Print Heads
- 100% Wrenchless™
- Micro Registration
- Ultimate Micros™
 - Dual Independent Off-contact Micro Adjustment
 - Screen Tilt Micro Adjustment
- Durable Powder Coated Finish
- 26" OD Screen Frame Capacity*
- 4, 6 or 8 Print Stations
- 4,6,8,10, 12 or 14 Print Heads
- 16" x 16" Shirtboards included for each print station**
- Adjustable Roller Bearing Cam Indexing (RB) or Spring Plunger Indexing (SP) System
- Positive Lock Indexing System
- Pedestal Style Base
- 2", 2.5" or 3" Diameter Shaft
- Leg Levelers

OPTIONS

- Side Clamps
- Universal Side Clamps
- Multitude of Different Sizes and Types of Pallets
- Jacket Hold Downs
- Aluminum Shirtboards
- Large Diameter Print Head Wheel
- Large Diameter Print Station
- Custom Print Stations
- Casters
- Custom Powder Coating colors / finishes



Copyright 2014 BWM/Hopkins, a division of Billington Welding & Manufacturing, Inc. All rights reserved. No information herein may be reproduced or used in any manner without prior, express written consent from BWM/Hopkins. BWM/Hopkins, a division of Billington Welding & Manufacturing, Inc. (hereinafter BWM/Hopkins), believes the information in this document to be accurate at publication and does not assume liability resulting from incompleteness or inaccuracy. BWM/Hopkins reserves the right to change features, options, and/or specifications without notice. No warranties of merchantability or fitness for a particular purpose are made or are to be implied from the information herein. BWM/Hopkins expressly disclaims any liability for damages, consequential or incidental, from purchase, installation, servicing, and/or use of any product/service based upon the information herein. Published 01/13/14.

ULTIMATE

UNIVERSAL NUMBER SYSTEM

The Fastest,
Smallest,
& Simplest Way
to Print Athletic
Garments

REDUCE *your*
PRODUCTION
TIME *by up to*



It's More Than Just A
Numbering Machine

Attaches to your
black clamp style press

Easily switch between
numbering & standard printing

Print logo & number without
garment leaving the press

print 2 color
2" to 12" numbers



You won't believe it
until you see it!
Scan to view a video
of the press in action, or visit
www.k2ultimate.com

Basic Package

- 1 Base Unit
- 1 Arm Unit,
- 1 Cabinet
- 2 Sets of Screens
(0 through 9)
one color any size and font



4/4 Ultimate / Athletic Printing Press

4 color 4 station, with standard micros
Base Unit included on Ultimate Press

- Designed for Athletic Printing
- Smaller print head wheel
- 78 INCH DIAMETER
- 100% Wrenchless Print Heads
- Micro Registration
- Leg Levelers
- Adjustable Print Station Tension
- A complete set of Shirt Boards

Options:

- Ultimate Micros
- Universal Side Clamps



Ultimate Numbering Machine
15 West Street, Rutland, VT 05701
Phone-877-258-2685, Fax - 802-855-8946
www.k2ultimate.com

RedAir Spot Dryer

REDAIR®



Scan to
view
product
info
online



The BWM/Hopkins REDAIR Flash Dryers are proven production dryers for surface curing most inks on printed apparel as well as other substrates. Using a combination of infrared (IR) energy and heated forced air, these units are designed to increase production output quickly, safely, and economically! It works by drawing ambient room air into the top of the IR panel through the fan. The energized IR panel super heats the air as the fan pushes it through a network of holes, out the bottom of the panel and onto the substrate. This combination of heated air and IR energy result in faster curing for increased output!

Whether you require a manual unit or an automatic, all BWM/Hopkins Redair Flash Dryers provide the printer with the features necessary to achieve the best and fastest curing results!

FEATURES & OPTIONS

- UL®, UL-C® & CE® Compliant
- Independent Adjustable REDAIR Control
- Air-Cooled Electrical Enclosure
- Circuit Breaker & Fuse Protected
- Height Adjustable IR Panel
- Full 90° Rotating Panel
- High Wattage IR Panel
- Locking Casters
- Over Platen Dwell Timer
- With Foot Pedal or Micro Switch Activation

SPECIFICATIONS

			Manual	Auto
16 X 16	110 V - 21 AMP	2400 WATT	✓	✓
20 X 20	220 V - 19 AMP	4200 WATT	✓	✓
24 X 24	220 V - 25 AMP	5500 WATT	✓	✓

Output wattage varies with input voltage

Universal Side Clamps



Scan to
view
product
info
online



Improve screen stability and reduce stress on screens with Universal Side Clamps.

- Fits most screens including aluminum, wooden frames, and roller frames
- Retrofits all BWM/Hopkins back clamp style presses, plus most other back clamp style presses.
- Quickly change from back clamp to side clamps
- Made from lightweight precision machined aluminum extrusion
- Available in custom widths



Copyright 2014 BWM/Hopkins, a division of Billington Welding & Manufacturing, Inc. All rights reserved. No information herein may be reproduced or used in any manner without prior, express written consent from BWM/Hopkins. BWM/Hopkins, a division of Billington Welding & Manufacturing, Inc. (hereinafter BWM/Hopkins), believes the information in this document to be accurate at publication and does not assume liability resulting from incompleteness or inaccuracy. BWM/Hopkins reserves the right to change features, options, and/or specifications without notice. No warranties of merchantability or fitness for a particular purpose are made or are to be implied from the information herein. BWM/Hopkins expressly disclaims any liability for damages, consequential or incidental, from purchase, installation, servicing, and/or use of any product/service based upon the information herein. Published 01/13/14.

Parts, Repairs & Refurnishing Services



BEFORE



AFTER

BWM/Hopkins offers parts and repairs on all our equipment. Our customer service department is here to help you identify and order the appropriate replacement parts for your press.

We also offer refurbishing of older presses to keep them working properly.

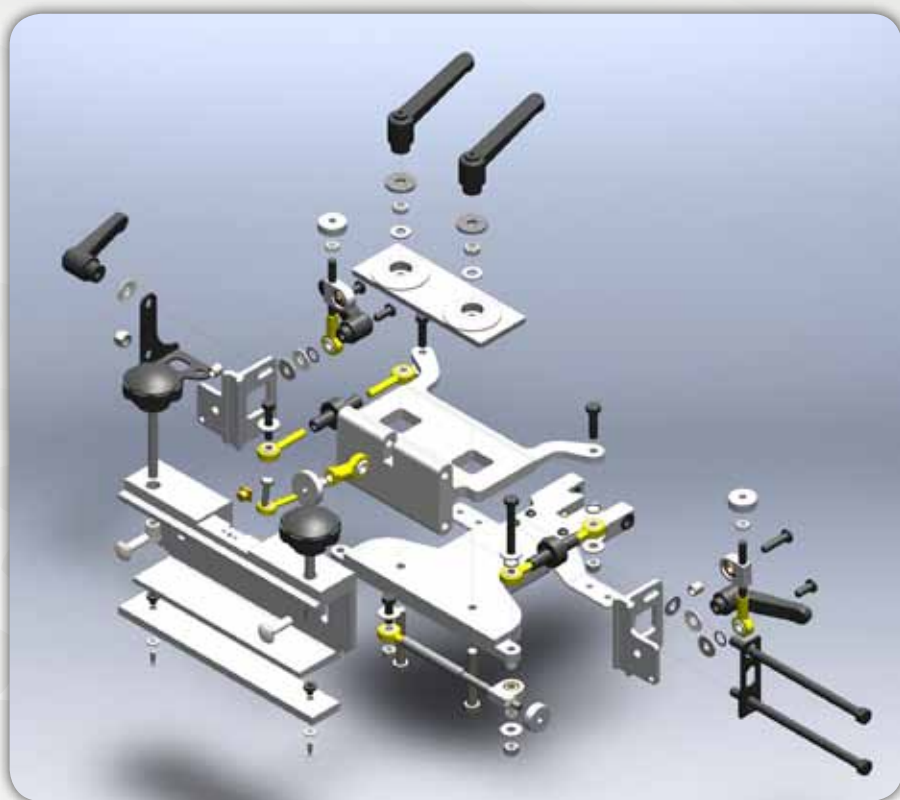

Shirt Boards & Hold Downs

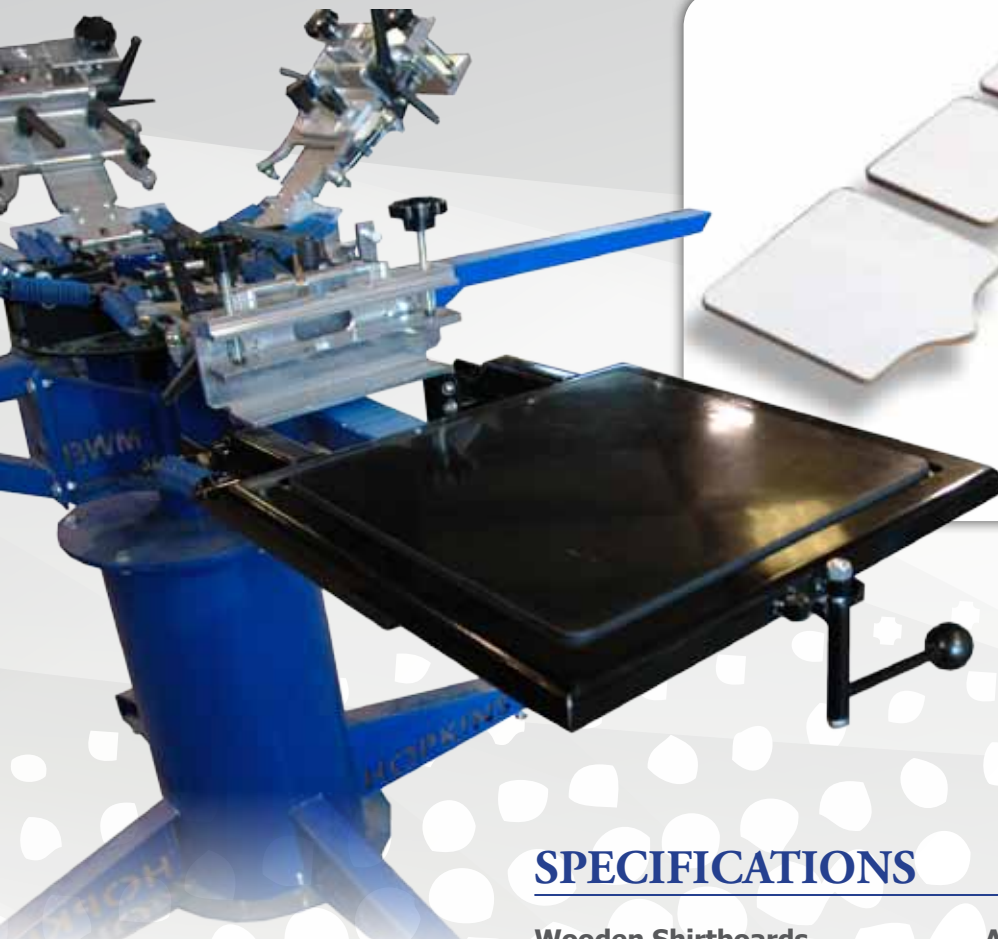

Shirtboards and shirtboard bracket assemblies are stock items. Specialty boards can be ordered, too. Plus, we stock sleeveboards, double sleeve assemblies and a wide choice of aluminum pallets. Contact your local supplier or call us for pricing and delivery.

SPECIFICATIONS

Wooden Shirtboards

Part #	Size
#33000	Bracket Assembly
#33008	8" x 10" w/bracket
#33009	10" x 10" w/bracket
#33010	12" x 14" w/bracket
#33011	14" x 14" w/bracket
#33012	16" x 16" w/bracket
#33013	18" x 18" w/bracket
#33014	15" x 20" w/bracket
#33016	7" x 33" w/bracket

Wooden shirt boards are also available without a bracket.

Wooden Sleeve Boards

Part #	Size
#33027	3" x 18-3/4"
#33028	4" x 18-3/4"
#33029	5" x 10"
#33032	5" x 18" w/bracket, tapered

Aluminum Shirtboards

Part #	Size
#33009AR	10" x 10" w/bracket
#33011AR	14" x 14" w/bracket
#33012AR	16" x 16" w/bracket
#33013AR	18" x 18" w/bracket

Aluminum shirt boards are available with or without an 1/8" rubber coating. Also available without a bracket.

Custom Hold Downs and Shirtboards

We manufacture all our shirt boards on site at our company headquarters. That means that we can build custom hold downs to suit your unique needs.





**1442 N. EMERALD AVE. | PO BOX 4460
MODESTO, CA 95352
209-526-9312 | 800-932-9312 | FAX 209-521-4759
INFO@BWMHOPKINS.COM | BWMHOPKINS.COM**